

**DXC910
OPERATIONS MANUAL**

**CRISIS ALERT
FOR
RM5000**

Contents

INTRODUCTION	4
FEATURES	5
STANDARD FEATURES	5
SYSTEM FEATURES	5
INDIVIDUAL FEATURES	5
NUMBER PLAN	6
IDLE:	6
PRIVACY:	6
CONVERSATION (INITIATOR):	6
CONVERSATION (RECEIVER):	6
FEATURES DESCRIPTION	7
HANDSFREE/LOUDSPEAKING	7
CONFIDENTIAL/SOFTSPEAKING	7
SIMPLEX	7
MICROPHONE CUTOFF	7
DIRECT DIALLING	7
DIRECT ACCESS	7
REMOTE CONTROL	8
CONFERENCE	8
CAMP ON BUSY EXTENSION	8
PRIVACY	8
PRIORITY	8
PERSONAL QUE	9
TRANSFER	9
ALL CALL	9
GROUP CALL	10
PROGRAM DISTRIBUTION	10
TWO WAY RADIO	10
TELEPHONE NETWORK	10
INTERSYSTEM TIE-LINE	11

CONFIGURATION	13
SYNTAX	13
TYPE FONTS	13
COMMAND	13
PROMPT	13
ERROR HANDLING	14
HELP	14
HELP COMMANDS	14
LIST COMMANDS	14
SET COMMANDS	15
PRIVILEGE TYPES	15
LINE EQUIPMENT	16
CALL NUMBER	16
CALLER ID	18
DEVICE TYPES	18
PRIVILEGE TYPES	19
DIRECT ACCESS	21
DIRECT DIAL	21
SUBSCRIBER TIMERS	22
PERSONAL QUE	23
TRANSFER	24
ANNUNCIATOR DISPLAY	25
EVENT LOG PRINTER	25
CAMERA SWITCHER.....	26
BATTERY CHARGER MONITOR.....	27
ALL CALL	28
GROUP CALL	28
BACKUP	30
INSTALLATION	32
POWER HOOKUP:.....	32
CRISIS ALERT NETWORK	32
SWITCH PROGRAMMING	33
RESET BATTERY RAM.....	33
PROCEDURE:	33
PCB500 INSTALLATION	35

INTRODUCTION

A standard RM5000 central is used as a basis for the DXC910 Crisis Alert system.

Some minor modifications are carried out on the NFE1643 board. A new pcb (DXC910) is replacing the old processor on the NFE1643 board. New software has been written for the new processor (68HC11) that includes standard intercom features, a new personal queue (replacement for CAS) and programming from a PC computer.

The DXC910 board includes a two wire data network (RS485) for connection of external annunciators (DAD104), log-printer interface (DNA100), PC interface (DNA100) video switcher interface (DNA200). This data network has capacity of eight devices. All devices are connected in parallel on the data pair (star or loop). Each device must be given a different network address (dip switch programming). The DXC910 sets its address on U49 (on NFE1643), the DAD104 has the switches (S1) located on the back, the DNA100 has the switches (SW2) located on the front panel. A typical system may use address:

08 for the DXC910

09 for the first DAD104

0A for the second DAD104

0B for the DNA100 at the PC

0C for the DNA200

0D for the DNA100 with a log-printer

(see the Network manual for setting network address).

The number of call digits are set by SW1 on the DXC910 card and the Battery RAM must be reset after changing number of call digits. All other programming is done from the PC connected to the DNA100. The PC can run Terminal for Windows 3.11, Hyperterm for Windows 95/98, Procomm + or any other emulation software with VT100 emulation.

When the PC is first connected to the DNA100 the Status Display screen will be displayed. Press CTR X on the PC to go to the main menu and select 6 - COMMUNICATIONS LINK.

You will now be asked for a network address. Enter **08** to program the DXC910 or **0C** to program the DNA200. The network will now set up a transparent link to the device that you want to program. See the appropriate device manual for programming details. Use the **SNA** command to associate an intercom station with a DAD104, printer or video monitor. Programming commands may be put in a text file in the PC and then uploaded to do the programming (> is the pace character).

The following manuals are available:

DXC910, Crisis Alert Interface for RM5000 (This manual)

DNA100, Digital Network Interface

DAD104, Digital Annunciator Display

NETWORK, Specification for the two wire Network

FEATURES

STANDARD FEATURES

- 3 Links
- Hands free Loudspeaking
- Confidential Softspeaking
- T-Button for manual control of speech direction
- Microphone mute
- Data transmission for remote control
- Privacy
- Camp on busy extension
- Crisis Alert Network Interface

SYSTEM FEATURES

- 2,3 or 4 Digit call numbers
- Program distribution (98)
- All Call (70)
- 7 Group Calls (71-77)
- Meet me (8-90)
- Battery Charger Alarm
- Event log printer interface (RS232)
- Video switcher interface (RS232)

INDIVIDUAL FEATURES

- Direct access
- 10 Direct dial
- Simplex always
- Multiparty conference (using single link)
- Assignable call numbers
- 12 Alphanumeric caller ID
- Personal queue for incoming calls
- Autodialer for use with TELCO interface
- External display of the personal queue (DAD104)
- 7 Transfer numbers for each subscriber (with programmable delay)
- Priority
- Line Supervision

NUMBER PLAN**IDLE:**

- 10-65 Subscriber number 2 digit dial
- 100-155 Subscriber number 3 digit dial
- 1000-1055 Subscriber number 4 digit dial
- 70 All Call
- 71-77 Group Calls
- 90 Respond to meet-me
- 95 Speed dial programming of telephone line interface
- 98 Program distribution

PRIVACY:

- 0 Accept call

CONVERSATION (INITIATOR):

- X Cancel call
- 8 Activate meet-me from Group Call or All Call
- 10-65 Add on conference 2 digit dial
- 100-155 Add on conference 3 digit dial
- 1000-1055 Add on conference 4 digit dial

CONVERSATION (RECEIVER):

- X Cancel call

FEATURES DESCRIPTION

HANDSFREE/LOUDSPEAKING

When two intercom stations are connected, either party may speak to the other hands free without touching any buttons.

CONFIDENTIAL/SOFTSPEAKING

At any time during the call, either one or both parties may pick up their station (AA904 or AA916) and use it as a handset for a confidential conversation. When both parties are in handset mode, the system operates in open duplex mode and both parties may talk and listen at the same time.

SIMPLEX

The T-button may be used to control the speech direction (push to talk release to listen). This is useful when one of the intercom stations are in a noisy area. Either party may use this function. If both stations are pushing the T-button the control is given to the station that pushed T last. Either party may revert to handsfree mode by tapping the T-button or touching the side strip on the AA904. Any call number may be programmed with the privilege "simplex always". When a call is placed from or to a station with the "simplex always" privilege, the initiator will be in listen mode and the T-button must be used to change the speech direction.

MICROPHONE CUTOFF

To temporary mute the microphone during conversation, the mute button may be pressed down.

DIRECT DIALLING

It is possible to program keys 0 to 9 of each intercom station's keypad to speed dial frequently called numbers. When a programmed key is pressed, a dialtone is heard as normal. If a second key is pressed within 1.2 seconds (programmable subscriber timer) then a normal dial sequence is taken.

DIRECT ACCESS

It is possible to program one call number for each intercom station to be activated by DC-shift. This type of calling is used with door stations and elevator stations that do not have a tone dialer.

REMOTE CONTROL

DTMF tones may be sent from one intercom station to the other for remote control. The keypad on the station sends standard telephone dialing tones (CCITT). This is mainly used for electric door-lock release and for dialling out to the public telephone network (PTT). The microphone mute function must be activated while pushing a number key to disable conference add-on . When the B-subscriber (receiver of the call) is programmed with the privilege “DTMF Device” then the number keys may be activated without pushing the microphone mute key.

CONFERENCE

When a station has the privilege “Conference Access” a multiparty conference is accomplished by dialling the extension of the party to add to the conference. There is no limit to the number of stations in the conference. The conference is simplex and use only one link. When more than one party is pushing the T-button the last one to push controls the microphone. The conference initiators T-button has priority. Conference participants may leave the conference by pushing X. The initiator may disconnect the last called station by pushing X, or disconnect the whole conference by dialing XX.

CAMP ON BUSY EXTENSION

The caller may camp-on to a busy extension for 15 seconds (programmable subscriber timer), after which the call will be automatically cancelled. If the called party becomes free within this time, the connection will be established with warning tone to both parties.

PRIVACY

The stations privacy switch controls the privacy status. When the B-subscriber is in privacy both stations gets the ringing tone. The B-subscriber may accept the call by pressing the 0-button within 15 seconds (programmable subscriber timer). This operation is valid when the B-subscriber is not using personal queue.

PRIORITY

When a station is programmed with the privilege “Priority” it may connect to a busy or privacy station by dialling “0” . This is only possible if the busy station does not have Priority privilege.

PERSONAL QUE

Each intercom station has a Personal Queue. This queue is activated with privilege "Personal Queue". All received calls are then put in the personal que and the intercom station will ring (2 second on, 3 second off) until the call is answered by pressing the 0-key. When the call is cancelled (X) the next call in queue starts ringing after 2 seconds (programmable subscriber timer). With the privilege "Automatic Answer" the call is automatically connected without pushing the 0-key.

Calls are inserted to the personal queue on a first in first out within each priority level (1-9). The priority level is the Call Priority of the calling station (level 1 is highest priority). The calling station may be connected to Ringing Tone, Program Channel or silence when in que. The personal queue may be displayed and answered on a DAD104.

TRANSFER

Call Transfer is used to distribute incoming calls to additional intercom station. Call transfer is using the personal que. Each subscriber may be programmed with 7 transfer numbers with delays. When a call is place to a intercom station with "personal queue" the call will be inserted in the personal que of the called station. When the transfer 1 delay expires the call will be placed in the personal que of the transfer 1 intercom station. The transfer 2 delay is then activated and when it expires the call is inserted in the personal que of the transfer 2 intercom station. This sequence is then repeated for transfers 3-7 if programmed. The incoming call is now in the personal queue of multiple intercom stations and when one of them answer the call it is removed from all the personal queues. The transfer delay is 0 - 9 minutes or infinite. If a transfer station is in privacy then the delay to that station is set to 0 and the call will transfer instantly (used for night transfer). Personal Queue is always used when calls transfer to another intercom station independent of the "personal queue" privilege.

ALL CALL

Allows for one way paging from one station to all other stations in the exchange and will override other calls (they will reconnect when the All Call is completed). The initiating station must have privilege "All Call Access". The duration of the All Call is limited to 60 seconds (programmable subscriber timer). The call number for All Call is 70. The All Call is terminated with X, or 8 for call back (meet me). One of the stations can then dial 90 to call back to the All Call initiator. The call back is active until one station dials 90 or a new call back is activated from another All Call or Group Call. It is possible to exclude receivers from the All Call. This is done by entering call numbers in the All Call exclusion group (group #0).

GROUP CALL

Allows for one way paging from one station to a group of stations and will override normal calls (they will reconnect when the Group Call is completed). The initiating station must have privilege "Group Call Access". The duration of the Group Call is limited to 60 seconds (programmable subscriber timer). There are 7 Group Calls in the system with access call numbers 71-77. The Group Call is terminated with X, or 8 for call back (meet me). One of the stations can then dial 90 to be connected to the Group Call initiator. The call back is active until one station dials 90 or a new call back is activated from another All Call or Group Call. Call number of the receivers are entered in the Group Call groups (group 1-7). All station may be a members of multiple Group Call groups. Only one Group Call can be active at a time. Stations calling Group Call when it is in use may camp on until it is free.

PROGRAM DISTRIBUTION

The system has one program channel for distribution of music or other programs source. The access code is 98. The connection to program distribution does not effect normal intercom operations. When a call is initiated or received, the music is put on hold until the call is completed and then it is automatically reconnected. The feature is enabled with dip-switch U48 no.3 and 4 on NFE1643.

TWO WAY RADIO

The RM5000 system may be connected to a radio base station for communication on a closed two-way radio network. An interface unit is required and is given an ordinary subscriber number. If the radio system is simplex PTT then the subscriber number should be programmed with privilege "Simplex Always" The radio receive signal may be connected to the program distribution channel for monitoring.

TELEPHONE NETWORK

An interface can be supplied to operate between the public telephone network and the RM5000. The interface is used to make calls from any intercom station to the telephone network and to make call from an outside telephone to any intercom station.

The interface may be used as a speed dialer to a telephone number used for answering intercom calls from elevator intercoms in a night transfer mode of operation. The device type of the interface is set to PTT, and the speed dial number is programmed from a telephone calling the interface (or from a AA916 plugget into the port instead of the telephone interface). The feature code for programming is 95 and the speed dial telephone number is then dialed in from the telephone (maximum 16 digits). Dip switch no. 2 on U48 must be on during this programming. A delay may be entered as *1 for one second delay to *9 for 9 second delay. Example: 95*29*31234567 will delay 2 seconds (waiting for dial tone), dial 9, delay 3 seconds, then dial 1234567. When a call enters the personal que of the interface it will speed dial the remote telephone number, connect the station in que to the telephone line and then wait for disconnect from the remote

telephone before releasing the connection between the interface and the intercom station. After 2 seconds (programmable subscriber timer) the next call in personal que will repeat the process.

If the interface does not have the privilege "Personal Queue" then calls made to the interface will not activate the dialer and the phone number must be manually dialed. If transfers are activated from other stations (lobby master), then these calls are automatically placed in the personal que of the interface and will use the speed dialer out on the telephone line. This way a motor room master may use the interface for manually dialed calls, while elevator intercoms that dial the lobby master will be transferred to the personal que of the interface and use the speed dialer. The lobby master may have a infinite transfer delay during the day when all calls are answered by the lobby master. At night the lobby master is placed in privacy and all calls are transferred to the telephone interface.

INTERSYSTEM TIE-LINE

Two or more RM5000 systems may be interconnected using a tie-line interface at each end of a 4 wire connection (CE921). The connection may be a leased line or a hard wired copper cable. The CE921 may be interfaced to fiber optic cable drivers.

Manual tie-line: The tie-line interface is connected as an ordinary subscriber (devicetype ICM). To dial a subscriber in the remote RM5000, first dial the call number of the local tie-line then dial the call number of the remote intercom station.

Automatic tie-line: The tie-line is programmed with device type = TIE.

The call numbers in the connected exchanges must be different. A tie-line's call number is the call number range of the call numbers at the other end of the tie-line.

Example: Exchange A may use call numbers 100-150, Exchange B may use call numbers 200-250 and Exchange C may use call numbers 300-350. To dial a subscriber in the remote RM5000, just dial the call number of the remote intercom station (direct access and direct dial may also be used). The call number of the calling station is sent over the tie-line to the receiving station and is displayed on the receiving stations annunciator display (DAD104). Personal que is used when multiple calls are placed to the tie-line. When the call in progress is completed then the next call in personal que automatically dials across the tie-line. When calls are queued up on both sides of a tie-line then call direction will alternate for each call. The tie-line can only handle one call at a time. When multiple calls are queued for the tie-line, only the first call in que will appear on the DAD104 at the other end of the tie-line. When this call is completed then the next call queued to the tie-line will appear on the DAD104. Calls are handled in priority order in the originating exchange. ALARM's from a station will appear as a "CALL" when received on the remote exchange. FAULTS's are not sent over tie-line and must be handled in the local exchange. Call priority is not transferred over the tie-line. The priority of the tie-line will be used for all calls received on the tie-line. The Calling stations call number is transferred, but alphanumeric text is not transferred. The alphanumeric text of the receiving tie-line is used for display.

Remote control (DTMF number 5) works across the tie-line.

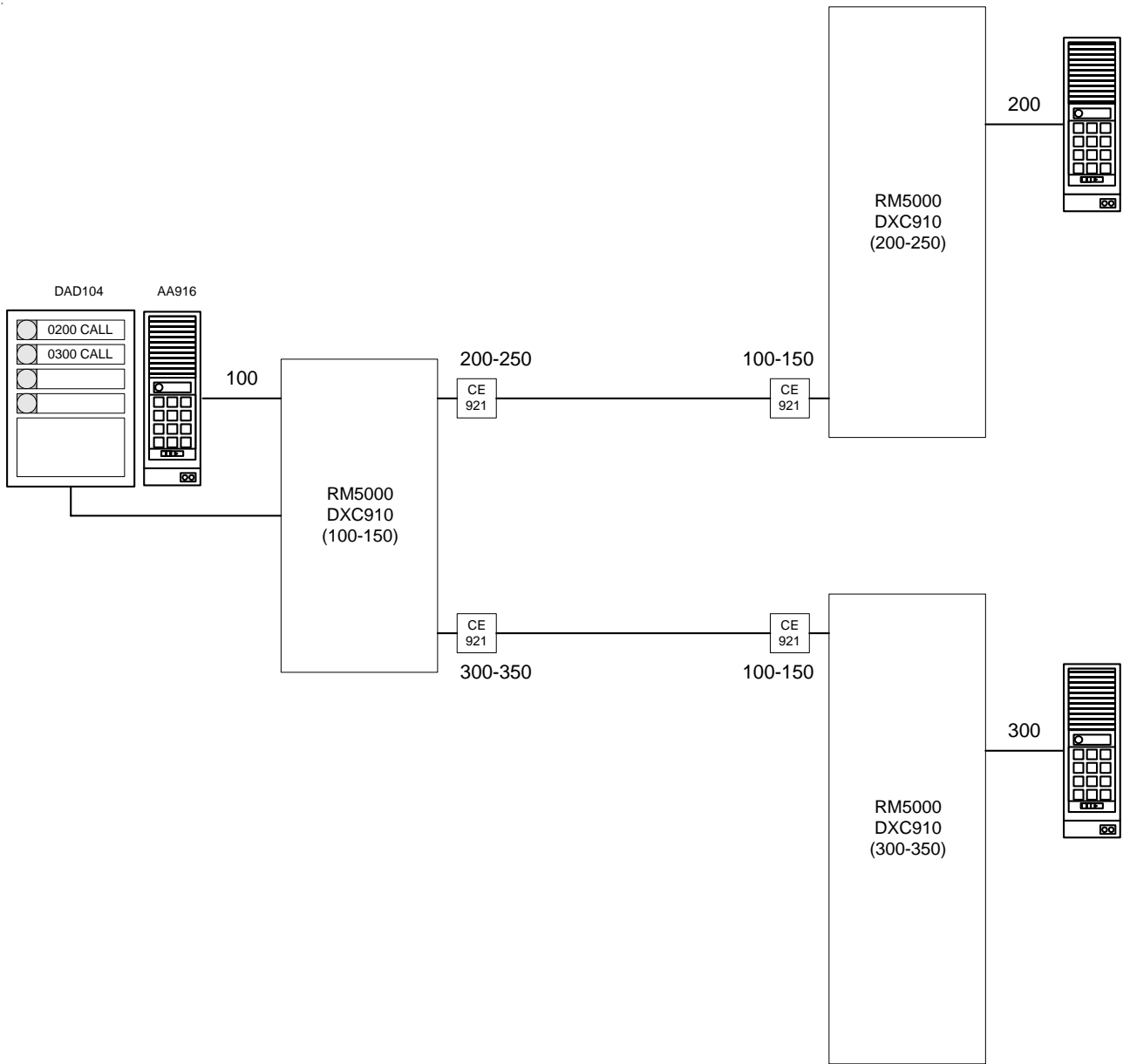

CONFIGURATION

One DNA100 is used as a programming interface to the DXC910. The DNA100 has one RS232 port for connection to dumb terminal or a PC running PROCOM+ emulating WYSE50 or VT100. Select main menu “6-COMMUNICATION LINK” on the DNA100 to sets up a link between the PC and the DXC910 (consult the DNA100 manual on the procedure to set up the communication link). The Configuration is done from the PC and the information is stored in battery RAM in the DXC910. When the system is first installed the RAM must be reset before the system is configured. After configuring the system the DNA100 may be removed.

SYNTAX

TYPE FONTS

boldface type _{cr}	indicates user input
Courier font	indicates output

COMMAND

The command consists of a command word plus one or more parameters.
The command may be entered on one line with the parameters separated by spaces.

>**command par1 par2 par3**_{cr}

The command may be entered in prompt mode with parameters separated by carriage return. The prompt will indicate what type of parameter value is required.

```
>commandcr
Prompt>par1cr
Prompt>par2cr
Prompt>par3cr
>
```

PROMPT

< >	Angle brackets enclose input parameters.
\$	Hexadecimal value (default is decimal).
-	Range of values may be entered.
..	Periods indicate that only ONE value is required from the range of values.
*	Wild card means all values in a range of values.

/ Optional input selection separator.
U Undefined

ERROR HANDLING

Misspelled command input will give the following error message:
Unknown Command
Parameter errors will print ERROR: and then prompt for the parameter again.

HELP

HELP COMMANDS

Help lists all help commands in the Configuration program. Type HELP, H or ?.

>**HELP**_{cr}

DXC910 Command Summary:

=====

HELP Help
H Help
? Help
HS Help Set Commands
HL Help List Commands
HPT Help Privilege Types
>

LIST COMMANDS

>**HL**_{cr}

DXC910 List Commands:

=====

LCN List Call Number
LDA List Direct Access
LDD List Direct Dial
LGCM List Group Call Members
LTN List Transfer Numbers
LLE List Line Equipment
LPT List Privilege Type
LST List Subscriber Timers
>

SET COMMANDS

>**HS**_{cr}

DXC910 Set Commands:

```
=====
SAP   Set Alarm Priority
SCN   Set Call Number
SCNU  Set Call Number Undefined
SCP   Set Call Priority
SCID  Set Caller ID
SDA   Set Direct Access
SDD   Set Direct Dial
SDT   Set Device Type
SGCM  Set Group Call Members
STN   Set Transfer Number
STD   Set Transfer Delay
SNA   Set Network Address
SPT   Set Privilege Type
SQP   Set QUE Program Channel
SST   Set Subscriber Timer
>
```

PRIVILEGE TYPES

>**HPT**_{cr}

ID Privilege

```
=====
1 Simplex Always
2 Voice Control A
3 DTMF Device
4 All Call Access
5 Group Call Access
6 Conference Initiator
7 Personal Queue
8 Automatic Answer
9 Priority Access
10 Line Supervision
>
```

LINE EQUIPMENT

The Line Equipment Number is the location of the intercom station in the central exchange. The number is hexadecimal in the range \$00-\$37 (56 stations). All individual station programming is done to this line equipment number. The programmed information may be listed by Line Equipment Number or by Call Number.

COMMANDS

LLE List Line Equipment (sorted by Line Equipment Number)
 LCN List Call Number (sorted by Call Number)

Example:

```
>LLEcx
Line Equipment Number <$00-$37/*> : 00-06cx
```

Line Equ.	Call Number	Caller ID	Type	In QUE	Priority Alarm	Call Annunciator	Printer	Video
\$00	10	Lobby	ICM	RING	1 3	0A	0B	...
\$01	11	Car 1A	ICM	1 5	...	0B	...
\$02	12	Car 1B	ICM	1 5	...	0B	...
\$03	13	Car 2A	ICM	1 5	...	0B	...
\$04	14	Car 2B	ICM	1 5	...	0B	...
\$05	15	MotorRoom	ICM	RING	1 3	...	0B	...
\$06	16	Phone Line	PTT	RING	1 3	...	0B	...

>

CALL NUMBER

Call numbers are assigned to all Line Equipment Numbers when the system is defaulted (network address set to \$00). The first Line Equipment will be call number 10, 100 or 1000 depending on the number of call digits in the system. All remaining line equipment numbers are assigned consecutive call numbers. These call numbers may be reassigned.

PROGRAMMING

The following commands are used for this feature:

SCNU Set Call Number Undefined
 SCN Set Call Number

Example: Change the call numbers from default 100-155 to 200-255. This is useful when two or more exchanges are connected via Tie-line. Use the R(range) option to assign call numbers to a range of line equipment numbers.

```
>SCNcr
Call Number <100-999/*> : 200-255cr
Line Equipment Number (R=range, S=single) <R/S> : Rcr
Line Equipment Number <$00..$3F> : 00cr
>LLEcr
Line Equipment Number <$00-$37/*> : 00-03cr
```

Line Equ.	Call Number	Caller ID	Type	In QUE	Priority Alarm	Call	Annunciator	Printer	Video
\$00	200		ICM	RING	1	3
\$01	201		ICM	RING	1	5
\$02	202		ICM	RING	1	5
\$03	203		ICM	RING	1	5

>

Example: Connect a Tie-line unit from the other exchange (100-155) to Line Equipment 00. Use the S(single) option to assign call numbers to a single line equipment number (the Tie-line).

```
>SCNcr
Call Number <100-999/*> : 100-155cr
Line Equipment Number (R=range, S=single) <R/S> : Scr
Line Equipment Number <$00..$3F> : 00cr
>LLEcr
Line Equipment Number <$00-$37/*> : 00-03cr
```

Line Equ.	Call Number	Caller ID	Type	In QUE	Priority Alarm	Call	Annunciator	Printer	Video
\$00	100--155		ICM	RING	1	3
\$01	201		ICM	RING	1	5
\$02	202		ICM	RING	1	5
\$03	203		ICM	RING	1	5

>

When calls are made to call numbers between 100 and 155 the Tie-line will send the calls to the other exchange.

CALLER ID

Each subscriber in the system has 12 alphanumeric characters for identification. This ID is available for display on the called station (DAD104) and for Event Logging (DNA100). Default is all spaces.

PROGRAMMING

The following commands are used for this feature:

SCID Set Caller ID
LCN List Call Number

Example: Set Caller ID for call number 14 to "Lobby".

```
>SCIDcr
Call Number <10-99/*> : 14cr
Caller ID <alphanumeric> : Lobbycr
>LCNcr
Call Number <10-99/*> : 14cr
```

Line	Call	In	Priority							
Equ.	Number	Caller ID	Type	QUE	Alarm	Call	Annunciator	Printer	Video	
\$04	14	Lobby	ICM	RING	1	5	

DEVICE TYPES

The device type defines the operation of intercom stations.

Type0 = Undefined
Type1 = SUB (DC shift substation)
Type2 = ICM (Master station or substation using speed-dial)
Type3 = PTT (Telephone line)
Type4 = TIE (Intersystem Tie-line)

PROGRAMMING

The following commands are used for this feature.

SDT Set Device Type
LCN List Call Number

```
>SDTcr
Call Number <10-99/*> : 11-14cr
Device Type (0=U 1=SUB 2=ICM 3=PTT 4=TIE) <0..4> : 1cr
```

>**LCN**_{cr}

Call Number <10-99/*> : **11-14**_{cr}

Line	Call			IN	Priority					
Equ.	Number	Caller ID	Type	QUE	Alarm	Call	Annunciator	Printer	Video	
====	=====	=====	====	====	=====	=====	=====	=====	=====	=====
\$01	11	Car 1A	SUB	RING	1	5	...	0B	...	
\$02	12	Car 1B	SUB	RING	1	5	...	0B	...	
\$03	13	Car 2A	SUB	RING	1	5	...	0B	...	
\$04	14	Car 2B	SUB	RING	1	5	...	0B	...	

>

PRIVILEGE TYPES

Privileges are assigned to each subscriber number for access to features of the system. Default has no privileges enabled.

PROGRAMMING

The following commands are used for this feature:

HPT Help Privilege Types
 SPT Set Privilege Type
 LPT List Privilege Types

Display all Privilege Types

>**HPT**_{cr}

ID	Privilege	
====	=====	
1	Simplex Always	A, B
2	Voice Control	A
3	DTMF Device	B
4	All Call Access	A
5	Group Call Access	A
6	Conference Access	A
7	Personal Queue	B
8	Automatic Answer	B
9	Priority	A
10	Line Supervision	

Example: Add All Call Access (Privilege 4) for Subscriber number 10.

```
>SPTcr
Call Number <10-99/*> : 10cr
Privilege ID <1..9> : 4cr
<+/-/=> : +cr
>
```

Display the result.

```
>LPTcr
Call Number <10-99/*> : 10cr
Privelege ID <1-9/*> : 4cr
```

```
Call Number  ID Privelege
=====
      10      4  All Call Access

>
```

PRIVILEGE DEFINITIONS

1. Simplex Always A,B:

This privilege will force simplex mode operation when this intercom is initiating or receiving a call. The initiator of the call will start in receive mode.

2. Voice Control:

The initiator of the call can use the *-key (DTMF) to control the speech direction. Each time the *-key is momentarily hit the speech direction changes. This is useful when telephones needs to control the simplex function.

10. Line Supervision:

A intercom station (ICM and SUB) with this privilege will be monitored. A fault is activated with open or shorted wires or loss of power to the intercom station. The fault is sent to the direct acces number programmed for this station.

DIRECT ACCESS

There is one direct access number for each subscriber (DC shift).

PROGRAMMING

The following commands are used for this feature.

SDA Set Direct Access
LDA List Direct Access

Example 1: Set direct access for subscriber 12 to dial subscriber 18.

```
>SDAcr
Call Number <10-99/*> : 12cr
Call Number to be dialed <10..99/U> : 18cr
>LDDcr
Call Number <10-99/*> : 12cr
```

```
Call Number   DA   DD-0 DD-1 DD-2 DD-3 DD-4 DD-5 DD-6 DD-7 DD-8 DD-9
=====
          12       18
```

>

DIRECT DIAL

There are 10 direct dial numbers for each subscriber (key 0-9).

PROGRAMMING

The following commands are used for this feature.

SDD Set Direct Dial
LDD List Direct Dial

Example 1: Set direct dial for subscriber 14 key #5 to dial subscriber 23.

```
>SDDcr
Call Number <10-99/*> : 14cr
Key Number <0..9> : 5cr
Call Number to be dialed <10..99/U> : 23cr
>LDDcr
Call Number <10-99/*> : 14cr
```

```

Call Number  DA  DD-0 DD-1 DD-2 DD-3 DD-4 DD-5 DD-6 DD-7 DD-8 DD-9
=====
          14                               23

```

>

SUBSCRIBER TIMERS

There are 8 timers that can be set individually for each subscriber. A timer value of 0 means no time limit.

PROGRAMMING

The following commands are used for this feature.

```

SST      Set Subscriber Timer
LST      List Subscriber Timers

```

Example: Set warning tone length (timer 2) to 1 sec. when subscriber 15 receives calls .

```

>SSTcr
Call Number <10-99/*> : 15cr
Timer ID <1..8> : 2cr
Timer Value <0....50> :10cr
>LSTcr
Call Number <10-99/*> : 15cr
Timer ID <1..8> : *cr

```

Call Number	ID	Timer		Setting	Resolution	Limit
14	1	Direct Dial	(A)	12	0.1 sec	30
	2	Warning Tone	(B)	10	0.1 sec	50
	3	Call Length	(A)		1.0 sec	240
	4	Group Call	(A)	60	1.0 sec	600
	5	All Call	(A)	60	1.0 sec	600
	6	PQUE Ring Delay	(B)	2	1.0 sec	240
	7	Camp on Privacy	(A)	15	1.0 sec	240
	8	Camp on Busy	(A)	20	1.0 sec	240

>

PERSONAL QUE

Each intercom station has a Personal Queue. This queue is activated with Privelege ID number 7. All received calls are put in personal que and the intercom station will ring (2 sec on, 3 sec off) until the call is answered by pressing the 0 key. When the call is cancelled (X) the next call in queue starts ringing after 2 seconds. This time is programmable (Timer ID number 6).

Calls are inserted to the personal queue on a first in first out within each priority level (1-9). The priority level is the Call Priority of the calling station (level 1 is highest priority). The calling station may be connected to Ringing Tone, Program Channel or silence when in que.

PROGRAMMING

The following commands are used for this feature

SPT	Set Privelege Type
SST	Set Subscriber Timer
SQP	Set Que Program Channel
SCP	Set Call Priority
LPT	List Privelege Type
LST	List Subscriber Timer
LCN	List Call Number

Example: Intercom station 10 is using personal queue to receive calls with 1 second delay between calls. Intercom stations 11-14 will get ringing tone when they call intercom 10. Intercom 11 will get calling priority 3 and intercom 12-14 will get priority level 4.

```

>SPTcr
Call Number <10-99/*> : 10cr
Privelege ID <1..7> : 7cr
<+/-/=> : +cr
>SSTcr
Call Number <10-99/*> : 10cr
Timer ID <1..8> : 6cr
Timer Value <0....240> : 1cr
>SQPcr
Call Number <10-99/*> : 11-14cr
Program Channel in QUE (0=None, 1=Program, 2=Ringback) <0..2> : 2cr
>SCPcr
Call Number <10-99/*> : 11cr
Priority Level <1..9> : 3cr
>SCPcr
Call Number <10-99/*> : 12-14cr
Priority Level <1..9> : 4cr
>

```

TRANSFER

Call Transfer is used to distribute incoming calls to additional intercom station. Each subscriber has 7 transfer numbers. Transfers are processed sequentially, transfer 1 must activate before transfer 2 is activated and transfer 3 will not activate until transfer 2 is activated and so on. With each transfer there is a delay before the call is transferred. The delay is in increments of 6 seconds :

00 = no delay,
 01 = 6 second delay
 20 = 2 minute delay
 98 = 9 minutes 48 seconds
 99 = infinite delay

If a transfer station is in privacy then the delay to that station is set to 0 and the call will transfer instantly (used for night transfer). Personal Queue is always used when calls transfer to another intercom station. When a call transfers it also remains in queue of the transferring station. The call can then be answered by the transferred station or by the transferring station .

PROGRAMMING

The following commands are used for this feature.

STN Set Transfer Number
 STD Set Transfer Delay
 LTN List Transfer Numbers

Example: Make calls to subscriber 14 transfer to subscribers 20 and 21 if subscriber 18 does not answer the call within 60 seconds.

```
>STNcr
Call Number <10-99/*> : 14cr
Transfer Number <1..7> : 1cr
Call Number to be dialed <10..99/U> : 20cr
>STN 14 2 21cr
>STDcr
Call Number <10-99/*> : 14cr
Transfer Number <1..7> : 1cr
Transfer Delay(6 sec) <00..99> : 10cr
>LTNcr
Call Number <10-99/*> : 14cr
```

```
Call Number TRFR: 1 TRFR: 2 TRFR: 3 TRFR: 4 TRFR: 5 TRFR: 6 TRFR: 7
(CN)     DLY--CN DLY--CN DLY--CN DLY--CN DLY--CN DLY--CN DLY--CN
=====
14       10---20 -----21 -----
>
```

ANNUNCIATOR DISPLAY

Any intercom station in the system may use an annunciator display (DAD104) to display and answer calls in the personal queue. Each DAD104 is assigned to only one intercom station.

PROGRAMMING

The following commands are used for this feature.

SNA Set Network Address
LCN List Call Number

Example: Subscriber 10 is assigned to the DAD104 with network address 0A (hex). The network address is set with DIP-switch in the DAD104.

```
>SNAcr
Call Number <10-99/*> : 10cr
Node Type (1=Annunciator 2=Printer 3=Video) <1..3> : 1cr
Network Address <$00..$FF> : 0Acr
```

EVENT LOG PRINTER

The event log printer is connected to the system using one dedicated DNA100. The printer will print events for all intercom stations that have been assigned to this printer.

PROGRAMMING

The following commands are used for this feature.

SNA Set Network Address
LCN List Call Number

Example: Subscribers 10-17 are assigned to log events to the printer with network address 0B (hex). The network address is set with DIP-switch in the DNA100.

```
>SNAcr
Call Number <10-99/*> : 10-17cr
Node Type (1=Annunciator 2=Printer 3=Video) <1..3> : 2cr
Network Address <$00..$FF> : 0Bcr
```

CAMERA SWITCHER

The camera switcher is connected to the system using one dedicated DNA200. The camera switcher will connect a camera to a video monitor when the call is answered by the intercom station equipped with a video monitor. Intercom stations with monitors are programmed with the address of the DNA200. Monitor address and camera address are programmed inside the DNA200 (see separate documentation).

PROGRAMMING

The following commands are used for this feature.

SNA Set Network Address

LCN List Call Number

Example: Subscribers 10 and 17 with monitors are assigned to camera switcher with network address 0C (hex). The network address is set with DIP-switch in the DNA200.

```
>SNAcr
Call Number <10-99/*> : 10cr
Node Type (1=Annunciator 2=Printer 3=Video) <1..3> : 3cr
Network Address <00..FF> : 0Ccr
>SNA 17 3 0Ccr
```

```
>LCNcr
Call Number <10-99/*> : 10-17cr
```

Line	Call			IN	Priority					
Equ.	Number	Caller ID	Type	QUE	Alarm	Call	Annunciator	Printer	Video	
====	=====	=====	====	====	====	=====	=====	=====	=====	=====
\$00	10	Lobby	ICM	RING	1	3	0A	0B	0C	
\$01	11	Car 1A	ICM	1	5	...	0B	...	
\$02	12	Car 1B	ICM	1	5	...	0B	...	
\$03	13	Car 2A	ICM	1	5	...	0B	...	
\$04	14	Car 2B	ICM	1	5	...	0B	...	
\$05	15	MotorRoom	ICM	RING	1	4	...	0B	...	
\$06	16	Phone Line	PTT	RING	1	4	...	0B	...	
\$07	17	Security	ICM	RING	1	2	...	0B	0C	

>

To remove an Annunciator, Printer or Video Monitor from an intercom station, set the network address of the device to 00.

BATTERY CHARGER MONITOR

When the RM5000 is equipped with battery backup the battery voltage is monitored. A treshold may be set with R6 to apx 25 Volt. If the voltage is higher then this treshold then the battery is being charged and D6 is ON. If AC power is lost or the battery charger fails then the battery voltage will rapidly fall below the treshold and D6 will turn OFF. At the same time an alarm may be sent to the DAD104 (if programmed) that the system is running on battery power. This alarm can only be cleared by restoring the battery voltage to 25 Volt or higer.

PROGRAMMING

The following commands are used for this feature.

SCN Set Call Number
 SCID Set Caller ID
 SNA Set Network Address
 LCN List Call Number

Example: Subscribers 10 has a DAD104 with network address 09 (hex). Power Fail Alarms from the DXC910 are to be sent to this DAD. First we assign call number 00 to the DXC910 at Line Equipment Number 4F(hex).

```
>SCNcr
Call Number <10-99/*> : 01cr
Line Equipment Number <$00..$3F> : 4Fcr
>SCID 01 RM5000cr
>SNAcr
Call Number <10-99/*> : 01cr
Node Type (1=Annunciator 2=Printer 3=Video) <1..3> : 1cr
Network Address <$00..$FF> : 09cr
>LCNcr
Call Number <10-99/*> : 01cr
```

Line Equ.	Call Number	Caller ID	In Type	Priority	Annunciator	Printer	Video
\$4F	01	RM5000	ICM RING	1 5	09

>

ALL CALL

Allows for one way paging from one station to all other stations in the exchange and will override other calls (they will reconnect when the All Call is completed). The initiating station must have privilege “All Call Access”. The duration of the All Call is limited to 60 seconds (programmable subscriber timer). The call number for All Call is 70. The All Call is ended with X for termination or 8 for call back (meet me). One of the stations can then dial 90 to call back to the All Call initiator. The call back is active until one station dials 90 or a new call back is activated from another All Call or Group Call. It is possible to exclude receivers from the All Call. This is done by entering call numbers in the All Call exclusion group (group #0).

PROGRAMMING

The following commands are used for this feature (see Group Call).

SGCM Set Group Call Members
LGCM List Group Call Members
SPT Set Privilege Type

GROUP CALL

Allows for one way paging from one station to a group of stations and will override normal calls (they will reconnect when the Group Call is completed). The initiating station must have privilege “Group Call Access”. The duration of the Group Call is limited to 60 seconds (programmable subscriber timer). There are 7 Group Calls in the system with access call numbers 71-77. The Group Call is terminated with X or 8 for call back (meet me). One of the stations can then dial 90 to be connected to the Group Call initiator. The call back is active until one station dials 90 or a new call back is activated from another All Call or Group Call. Call number of the receivers are entered in the Group Call groups (group 1-7). All station may be a members of multiple Group Call groups. Only one Group Call can be active at a time. Stations calling Group Call when it is in use may camp on until it is free.

PROGRAMMING

The following commands are used for this feature.

SGCM Set Group Call Members
LGCM List Group Call Members
SPT Set Privilege Type

Example 1: Exclude stations 10 and 11 from All Call #0 (70).

```
>SGCMcr  
Call Number <10-99/*> : 10-11cr
```

```

Group Number <0..7> : 0cr
<+/-/=> : +cr
>

```

Example 2: Include stations 12-26 in Group Call #3 (73).

```

>SGCMcr
Call Number <10-99/*> : 12-26cr
Group Number <0..7> : 3cr
<+/-/=> : +cr
>

```

Example 3: Exclude stations 15 from Group Call #3 (73).

```

>SGCMcr
Call Number <10-99/*> : 15cr
Group Number <0..7> : 3cr
<+/-/=> : -cr
>

```

Example 4: Include stations 18 only in Group Call #6 (76).

```

>SGCMcr
Call Number <10-99/*> : 18cr
Group Number <0..7> : 6cr
<+/-/=> : =cr
>

```

Display the result of example 1 - 4.

```

>LGCMcr

Group  Call
Number Number  Receivers
=====
 0 -    70      10  11
 1 +    71
 2 +    72
 3 +    73      12  13  14  16  17  19  20  21  22  23
                24  25  26
 4 +    74
 5 +    75
 6 +    76      18
 7 +    77
>

```

BACKUP

Backup generates programming commands required to restore the configuration of the DXC910. These commands may be downloaded and stored in a file on the PC. This file can then be uploaded to restore the configuration of the DXC910.

PROGRAMMING

The following command is used for this feature.

BAK Backup

Example:

```
>BAKcr
Call Number <100-999/*> : 100-101cr
!
!   BACKUP START: 2007/05/17
!
! DXC910 VERSION: 2007/04/16
!
SCN 10 00
SCID 10 SECURITY
SDT 10 2
SQP 10 2
SAP 10 1
SCP 10 5
SCN 11 01
SCID 11 EAST GATE
SDT 11 2
SQP 11 2
SAP 11 1
SCP 11 5
!
! END OF TRANSFER
```

Software Version 2002/10/04.

Commands generated by the backup command:

SAP Set Alarm Priority
SCN Set Call Number
SCP Set Call Priority
SCID Set Caller ID
SDT Set Device Type
SQP Set QUE Program Channel

Commands not generated:

SCNU Set Call Number Undefined
SDA Set Direct Access
SDD Set Direct Dial
SGCM Set Group Call Members
STN Set Transfer Number
STD Set Transfer Delay
SNA Set Network Address
SPT Set Privilege Type
SST Set Subscriber Timer

INSTALLATION

POWER HOOKUP:

Use DC power supply.

Connect Ground (minus) to	TB1 pin 3
Connect +24VDC to	TB1 pin 4

CRISIS ALERT NETWORK

The DXC910 has a one pair RS485 bidirectional port for communication with Crisis Alert Devices:

DNA100	Used for programming or for interfacing to Log Printer
DAD104	Annunciator Display
DS16	Direct select Annunciator, 16 line
DNA200	Camera switcher interace

The DXC910 has 3 LEDs for displaying network communication:

D5	Master LED.	This LED is ON if the DXC910 is the Master on the Network.
D4	TX Data.	Blinks when DXC910 transmit to the network.
D3	RX Date.	Blinks when other devices transmit to the network.

SWITCH PROGRAMMING

U49 on NFE1643 is the crisis alert network address.

Network 1 Node 0 is normally used (Address \$08):

1	2	3	4	5	6	7	8
OFF	OFF	OFF	ON	OFF	OFF	OFF	OFF

U48 on NFE1643 has the following feature enabled when set to position ON:

- 1 Not used
- 2 Enable speed dial programming from telephone line or master station
- 3 Enable Program distribution (music)
- 4 Enable Program distribution (music)

SW1 on PCB500 (DXC910) is used for selecting number of digits in call numbers when the system is defaulted.:

- | | | |
|-----|-----|--|
| 1 | 2 | |
| OFF | OFF | Special preprogrammed configuration (Reserved) |
| OFF | ON | 2 Digit Dialing (10-55) |
| ON | OFF | 3 Digit Dialing (100-155) |
| ON | ON | 4 Digit Dialing (1000-1055) |

RESET BATTERY RAM

The Battery RAM must be initialized when the system is first installed. All programmable features are set to default and all station are assigned call numbers .

PROCEDURE:

1. Set all 8 dip switches in U49 (NFE1643) to OFF.
2. Set SW1 (DXC910) for number of call digits.
3. Push and release the Reset Switch on NFE1643 (SW2).

LED D5 (DXC910) will blink 4 times during RAM Test (apx. 4 sec.).
The RAM will initialize (2 sec.).

D5 will flash rapidly to indicate that the initialization is complete.

4. Set U49 (NFE1643) to proper network address (turn switch 4 ON)
5. Push and release the Reset Switch on NFE1643 (SW2).

LED D5 (DXC910) will blink 4 times during RAM Test (apx. 4 sec.).
The system is now operational.

RM5000/DXC910 Cabling

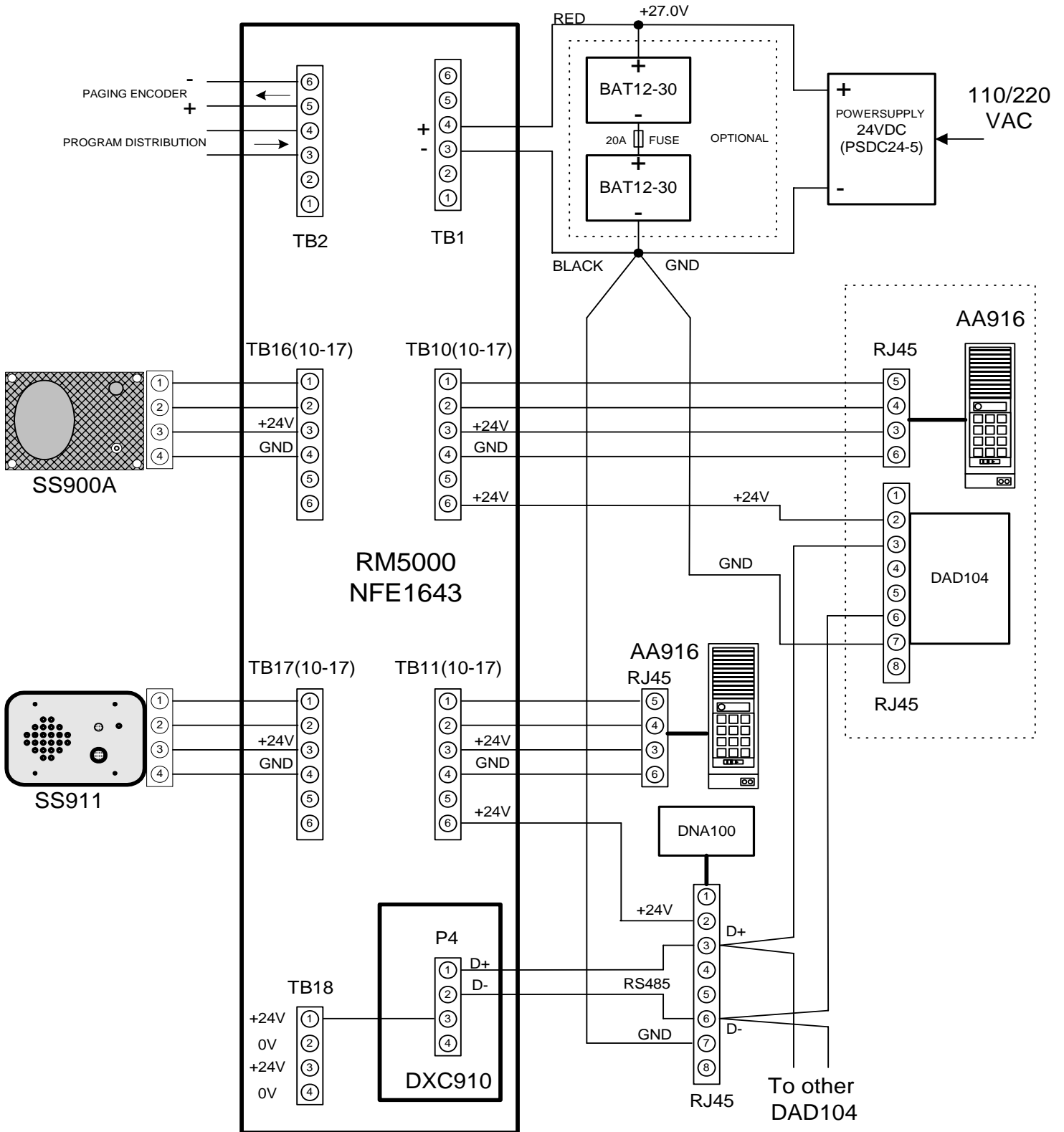

PCB500 INSTALLATION

NFE1643 MODIFICATIONS:

Remove Capacitor on U41 pin 14.
 Remove U41
 Remove U32
 Remove wire U41 pin 15 to ST 6
 Remove ST4
 Cut ST9
 Cut Test Pins TP7 and TP8 (interference with PCB500)
 Bend C48 away from U43 (interference with PCB500)
 Insert 16 pin IC socket in U41
 Insert ST5
 Insert ST7
 Insert ST8
 Disconnect U51 pin 1 from VCC
 Disconnect U51 pin1 from U51 pin 28
 Connect U51 pin 28 to VCC
 Connect U51 pin 1 to Address Line A14 (U32 pin 24)
 Replace U51 (Ram) with DS1230 (32Kb)
 Replace U50 (EPROM) with 27C256 (32Kb)
 Replace R59 with Strap (increase DTMF output in USA)
 Strap D15
 Place plastic insulator on metal edge next to U41
 Insert PCB500 to NFE1643 U32/U41

The Power to the RM5000 must be changed when used with the DXC910.

The Ground in the RM5000 and the Ground to the DNA100 and DAD104 must be common.

Use DC power supply.

Connect Ground (minus) to TB1 pin 3

Connect +24VDC to TB1 pin 4

The Power Switch in the RM5000 will now switch the plus 24V DC instead of the minus.

FINAL STRAP CONFIGURATION:

ST4	ST5	ST6	ST7	ST8	ST9	ST10	ST11
OUT	IN	OUT	IN	IN	OUT	OUT	IN

ADDRESS MAP:

U51	RAM	32K	\$0000-\$7FFF
U45	DTMF TX		\$8400-\$87FF
U31	PIA 1		\$8800-\$8BFF
U30	PIA 2		\$8C00-\$8FFF
U50	EPROM 32K		\$A000-\$FFFF

