

DS16

OPERATIONS MANUAL

CRISIS ALERT
Direct Select Annunciator
16 Button

Table of Contents

INTRODUCTION.....	5
INSTALLATION.....	5
INTRODUCTION.....	5
OPERATION	7
CONFIGURATION.....	9
HELP.....	10

CRISIS ALERT

DS16

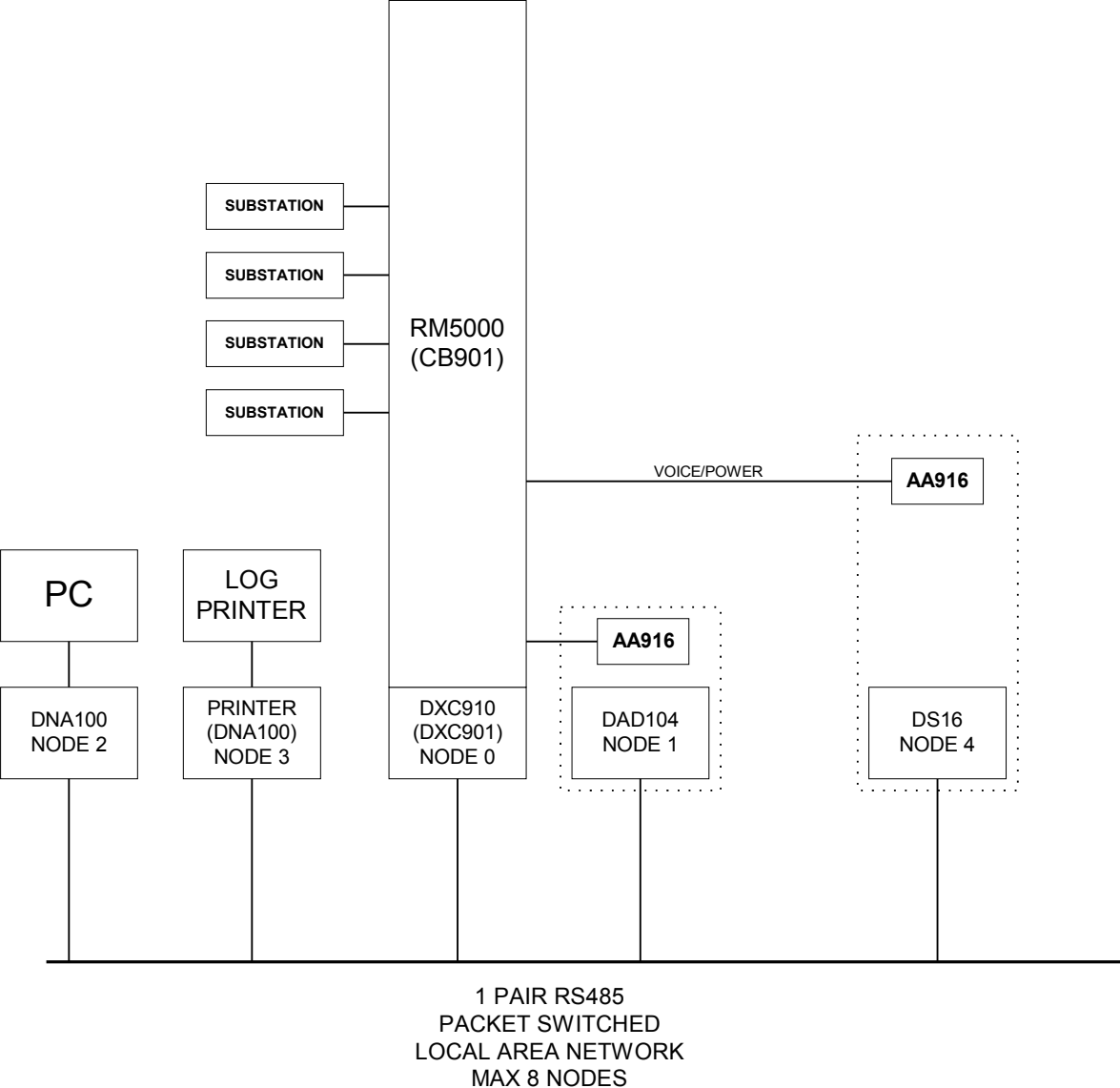

INTRODUCTION

The DS16 can be interfaced to the Crisis Alert Network for the purpose of handling incoming and outgoing calls associated with one of the Crisis Alert master stations.

Each DS16 must be assigned to a master station in the RM5000EX or CB901EX (the same way as when using DAD104).

INSTALLATION

INTRODUCTION

The DS16 operates on +24 VDC. It can be powered from the central exchange or can be powered locally by a separate 24 VDC regulated power supply.

The recommended cord is the BF640A to connect the DS16 to the RJ45 network jack, KB171. Cords and jacks must be ordered separately.

One modular jack is provided at the back of the DS16. **Use modular cables with straight through pin configuration only!** An 8-pin (RJ45) modular jack (KB171) and cord (BF640A) are required for connection to the network.

PIN# - DESIGNATION

- 1 - No connection.
- 2 - +12 VDC power input
- 3 - Data + (positive)
- 4 - No connection.
- 5 - No connection.
- 6 - Data - (negative)
- 7 - -12 VDC power input
- 8 - External Alarm.

The maximum total network length is 7000 feet. A unshielded twisted pair cable should be used for the data pair (24 or 22 AWG).

Connect the DATA pair from the network to pins 3 and 6 of the RJ45 wall jack maintaining polarity of the pair. If a remote power source is being used, the negative side of the supply must be referenced to Earth Ground, as well as, the CB901/RM5000 power supply.

Clear Memory: Set DIP switch SW2 1-8 to off . Push RESET. Master light will start to flash when done. Set Network and Node Address. Push Reset. The DS16 is now ready to be configured.

Preset Memory: Set DIP switch SW2 1-8 to on . Push RESET. Master light will start to flash when done. Set Network and Node Address. Push Reset. The DS16 now has buttons 1-8 configured for call numbers 11-17.

DIP switch SW2 is used to set the address of the DS16. See [SETTING NETWORK ADDRESS](#) of Chapter A -[NETWORK](#) for a full description for setting addresses, as well as, an addressing chart.

SWITCHES

- SW1 - Reset. Creates a local reset for this node only.
- SW2 - Node & Network Address

L.E.D.'s

- RUN - Indicates the local processor in the DS16 is running. Will illuminate after power up or reset.
- MAST - Will light steady if this node is the master on the network. There can only be one master on each network. On power up, each device waits for a response from a master. If no response is received, then this device will take over as a master. Therefore, the first device powered up will be the master.
- TX - Transmit data to the Network. Will flash when the DS16 sends data out on the Network. If the Master LED is on, the TX LED will flash constantly. When the Master LED is off, TX will only flash when transmitting to other devices.
- RX - Receive data from the Network. Will flash when data is transmitted from another device to the network. If the Master LED is on, the RX LED will flash when other devices respond to scanning from the Master. When the Master LED is off, the RX LED will flash constantly.

OPERATION

DIRECT SELECT BUTTONS

The DS16 has 16 buttons used for receiving or placing calls. Each button has a status light.

The buttons are addressed in HEX from 0 to F.

Button 0 is upper left and button F is lower right. Call numbers may be programmed to buttons 1-F.

After a call button is programmed it can be used for answering or placing a call to the programmed call number.

Button 0 is used for answering calls from call numbers that have not been programmed to any of the buttons, and the call number of the calling station will displayed on the four digit numeric display.

FEATURE BUTTONS

The DS16 has 4 buttons used for call handling.

P: Park

X: Cancel

R: Remote control

BLANK: Not used

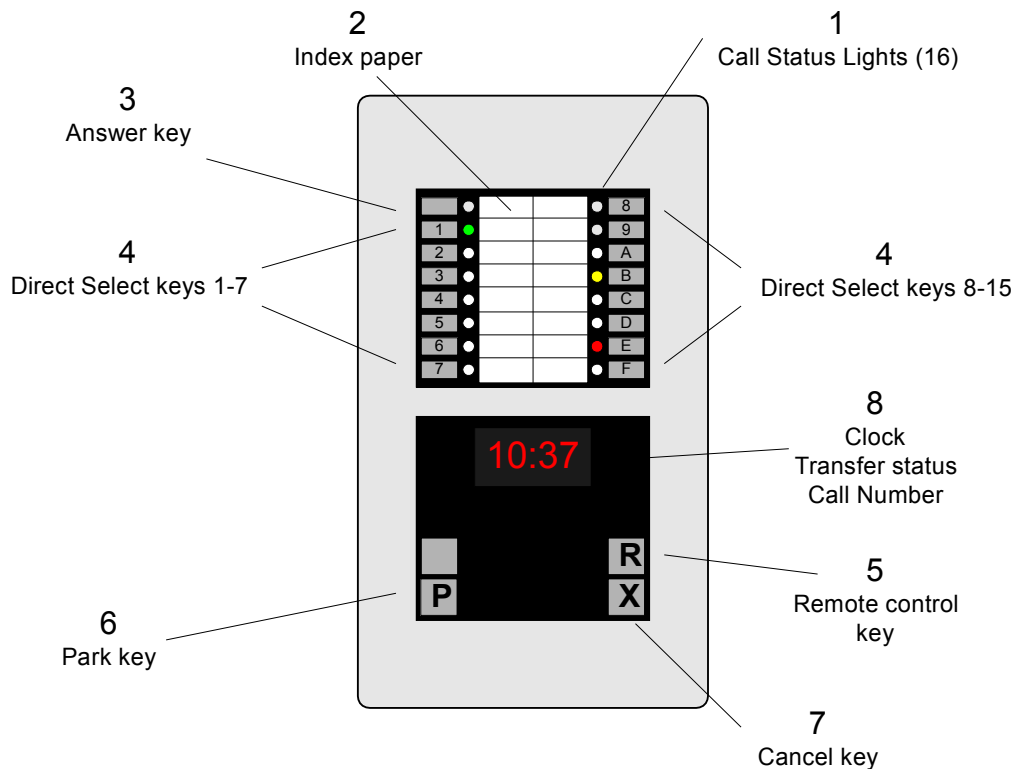

STATUS LIGHTS

Blinking Orange:	Incoming Call or Alarm
Solid Red:	Logged Off
Blinking Green:	Logged In
Blinking Orange:	Incoming Call or Alarm
Blinking Red:	Incoming Fault
Solid Green:	Call or Alarm or Fault has been answered on this DS16.
Solid Orange:	Call or Alarm or Fault has been answered by another station.
Flashing Orange:	Parked (on hold)

LED/KEY TEST

The test program is accessed with the following key sequence:

P-R-P-R

All lights turn on for the direct select keys Red+Green=Orange and 88:88 in the display.

When one of the Direct select keys is pushed the corresponding light turns Green, and all the other lights turn Red.

If no keys are pushed for 10 seconds the DS16 returns to normal operation.

OPTION MENU

The menu is accessed when pushing the blank key while in LED test mode.

Direct select 0-6 are used for selecting menu options.

0-Adjust Year

1-Adjust Month

2-Adjust Day

3-Adjust Hour

4-Adjust Minute

5-Adjust Second

6-Enable/Disable Time Display

Blank key = Increment

Park key = Decrement

CONFIGURATION

One DNA100 is used as a programming interface to the DS16. The DNA100 has one RS232 port for connection to a PC running PROCOM+.

The DNA100 sets up a link between the PC and the DS16 on the RS485 network. The Configuration is done from the PC and the information is stored in battery RAM in the DS16. When the system is first installed the RAM must be reset before the system is configured (described earlier in this section). After configuring the system the DNA100 may be removed.

SYNTAX

TYPEFONT

boldface type _{cr}	indicates user input
Courier font	indicates output

COMMAND

The command consists of a command word plus one or more parameters.

The command may be entered on one line with the parameters separated by spaces.

>**command par1 par2 par3**_{cr}

The command may be entered in prompt mode with parameters separated by carriage return. The prompt will indicate what type of parameter value is required.

```
>commandcr
Prompt>par1cr
Prompt>par2cr
Prompt>par3cr
>
```

PROMPT

< >	Angle brackets enclose input parameters.
\$	Hexadecimal value (default is decimal).
-	Range of values may be entered.
..	Periods indicate that only ONE value is required from the range of values.
*	Wild card means all values in a range of values.
/	Optional input selection separator.

ERROR HANDLING

Misspelled command input will give the following error message:

Unknown Command

Parameter errors will print ERROR: and then prompt for the parameter again.

HELP

Help lists all help commands in the Configuration program. Type HELP, H or ?.

>**HELP**_{cr}

```
DS16 Command Summary:
=====
H      Help
?      Help
LCN    List Call Numbers
LBA    List Pushbutton Address
SCN    Set Call Numbers
BAK    Backup
RST    Reset
>
```

CALL NUMBERS

All intercom stations are assigned call numbers in the Ring intercom central exchange.

The DS16 interface assigns a Push Button Address to each of the intercom call number for the external device. This assignment is stored in the DS16 and may be listed with the command **LCN** from the PC connected to the DNA100.

The call number may be 2,3 or 4 digit decimal.

The Push Button address is 1 digit HEX.

The Button may be removed from a a call number by entering 0 as the address.

>**LCN**_{cr}

Call Number <1-9999/*> : **10-20**_{cr}

Intercom Call Number	Button Address	NetSub Address
11	1	801
12	2	802
13	3	803
14	4	804

>

Note! The NetSub is the Network Address and Line Equipment Number of the intercom station. This information is used for testing only.

BUTTON ADDRESS

Assign a Push-Button to an intercom station.

PROGRAMMING

The following commands are used for this feature.

SBA Set Button Address

LCN List Call Number

Example: Set call number for intercom 11 to button address 1.

>**SCN**_{cr}

Call Number <1..9999/*> : **11**_{cr}

Button Address <0..2F> : **1**_{cr}

>**LCN**_{cr}

Call Number <1-9999/*> : **11**_{cr}

Intercom Call Number	Button Address	NetSub Address
=====	=====	=====
11	1	

>

BACKUP

Backup generates all programming commands required to restore the configuration of the DS16. These commands may be downloaded and stored in a file on the PC. This file can then be uploaded to restore the configuration of the DS16

PROGRAMMING

The following commands are used for this feature.

BAK Backup

Example:

```
>BAKcr
Call Number <1..9999>/*>: *cr
!
!   BACKUP START: 2012/04/23
!
! DS16 VERSION: 2012/02/21
!
SCN  11   1
SCN  12   2
SCN  13   3
SCN  14   4
!
! END OF TRANSFER
```